

YOGITECH's eVerification Components (eVCs) are scalable, configurable, plug-and-play, pre-verified and extensible verification environments that can be readily integrated into your design. They maintain full compatibility with Verity's Specman Elite test bench automation tool providing a solid basis in order to realize a complete, reliable and re-usable verification strategy increasing the verification team's productivity and the product's quality. Being **YOGITECH** in the Verification Alliance, its eVC's are interoperable with further releases of Verity's Specman Elite, avoiding eventual work misalignments between verification teams and projects. **YOGITECH's** proven protocol expertise assures a high reliability of its eVCs that are all eReuse methodology (eRM) compliant. **YOGITECH's** eVCs are exhaustively documented and tested. Through YOSS (**YOGITECH's** online support system), the company provides online support, documentation downloads, FAQ, examples and enquiries in a timely manner.

CAN 2.0 B evc

CAN 2.0B eVC is an advanced solution in the market for the verification of CAN 2.0B implementations. It is adherent with CAN 2.0B eVC (plus addendum specification) and it supports both standard and extended frames. It is able to generate all frame types such as data, remote, overload and error frames. The highest functional coverage is achieved by a complete built-in set of predefined coverage items. The eVC also embeds a powerful protocol-checker, fully compliant with CAN 2.0B specification.

CAN 2.0B eVC includes an extensive test suite covering most of the possible scenarios and CAN conformance norms. CAN 2.0B eVC is able to perform all protocol tests as testbench Bosch and moreover it allows an easy generation of a very high number of patterns and a set of specified patterns to stress the DUT. CAN 2.0B eVC verifies the conformance of the CAN implementation during the design phases using the modern verification methodology.

With CAN 2.0B eVC you'll improve time to market and the reliability of new CAN products.

MAIN FEATURES

- _ Adherent to CAN2.0B Specification. Data, Remote, error and overload frames fully supported.
- _ Supports generation of frames with error and noise injection.
- _ Tracking of the transmit and receive counters.
- _ Protocol Checker fully compliant with CAN 2.0B specification.
- _ Functional Coverage Measure. Built-in set of predefined coverage items.
- _ Database of predefined Sequences. Tuneable level of randomisation.
- _ Configurable as agent (frame generator) or monitor only.

DELIVERABLES

- _ Core Files. eVC Inner Layer encrypted. eVC Upper Layer fully configurable by the user.
- _ Support Files. Database of predefined CAN sequences. Sample and extensive tests covering basic functionality and CAN conformance norms.
- _ Documentation. Comprehensive User Guide including Release Notes. FAQ.
- _ Online Support Service. Fast bug fixing. General problem solving. Direct interaction with the product's development team.
- _ Training on demand.

CAN 2.0B eVC

eVC Architecture

CAN 2.0B eVC provides much more than a simple BFM. It is an eRM verification component composed by a configurable number of CAN agents, able to generate and inject frames or respond to frame requests according to CAN specification. Each frame can be customized in order to generate all the possible id, data length, data etc. CAN 2.0B eVC includes a monitor that logs all traffic information and collects items for test functional coverage. The embedded protocol checker is a runtime tool checking CAN rules of the current bus traffic. If some wrong conditions are detected during simulation, the checker prompts the user about the error. The eVC is completed by a noise and fault injector which is useful to verify CAN's synchronization.

eVC Usage

CAN 2.0B eVC can be used to verify module level CAN interfaces in the network verification environment with multiple CAN nodes and bridges. In fact, CAN 2.0B eVC is easily configurable due to its comprehensive top-level structure: CAN 2.0B eVC agents can be used to initiate and receive transactions at different levels of abstraction, the monitor and protocol checker can be used to verify the protocol compliance and to collect data for data logging. The eRM compliance assures that multiple instances of verification components can be managed by a top-level virtual sequence driver that generates and controls all the different possible verification scenarios: examples of such top-level environment are delivered together with the eVC. CAN 2.0B eVC is interoperable with Bosch Reference model (the only CAN verification environment available today): in fact the monitor and the protocol checker can be instantiated to collect traffic information between the DUT and the Bosch testbench.

Licensing

Yogitech's eVCs are distributed with a simple floating license which allows for multiple eVCs instantiations. Each Specman Elite license requires a separate eVC licence.

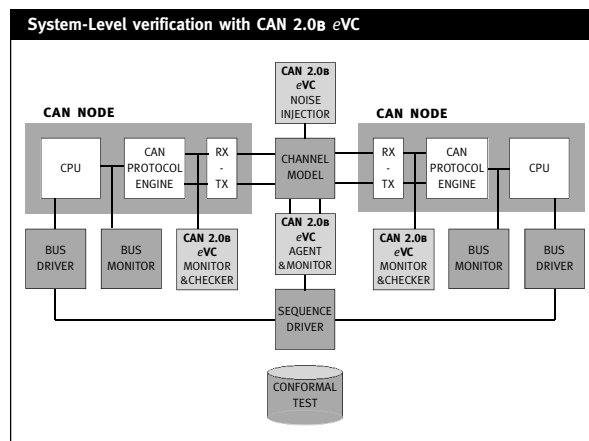
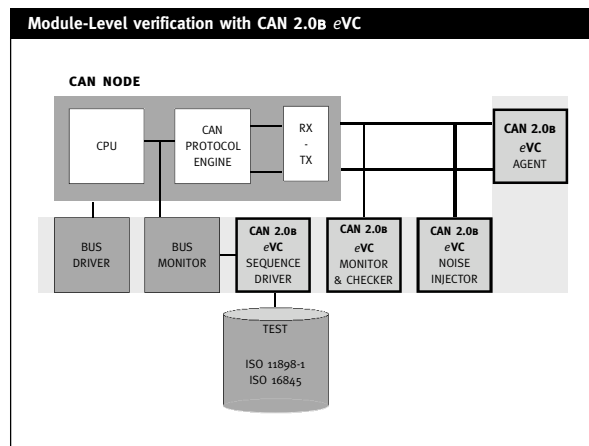
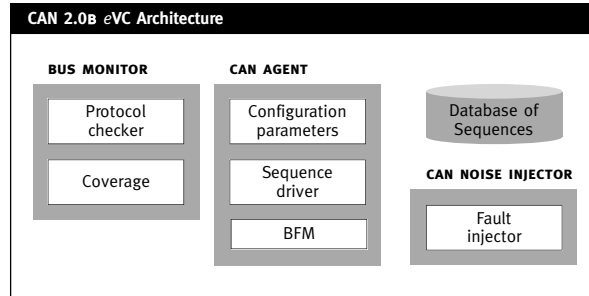

The product described in this document is subject to continuous development and improvements. Software licenses subject to availability. Yogitech reserves the rights to make any changes in this document and related product in any time without prior notice. No responsibility is accepted for errors or omissions.